

Starters

Overview

Siemens caters with following types of starters to agricultural and industrial sector.

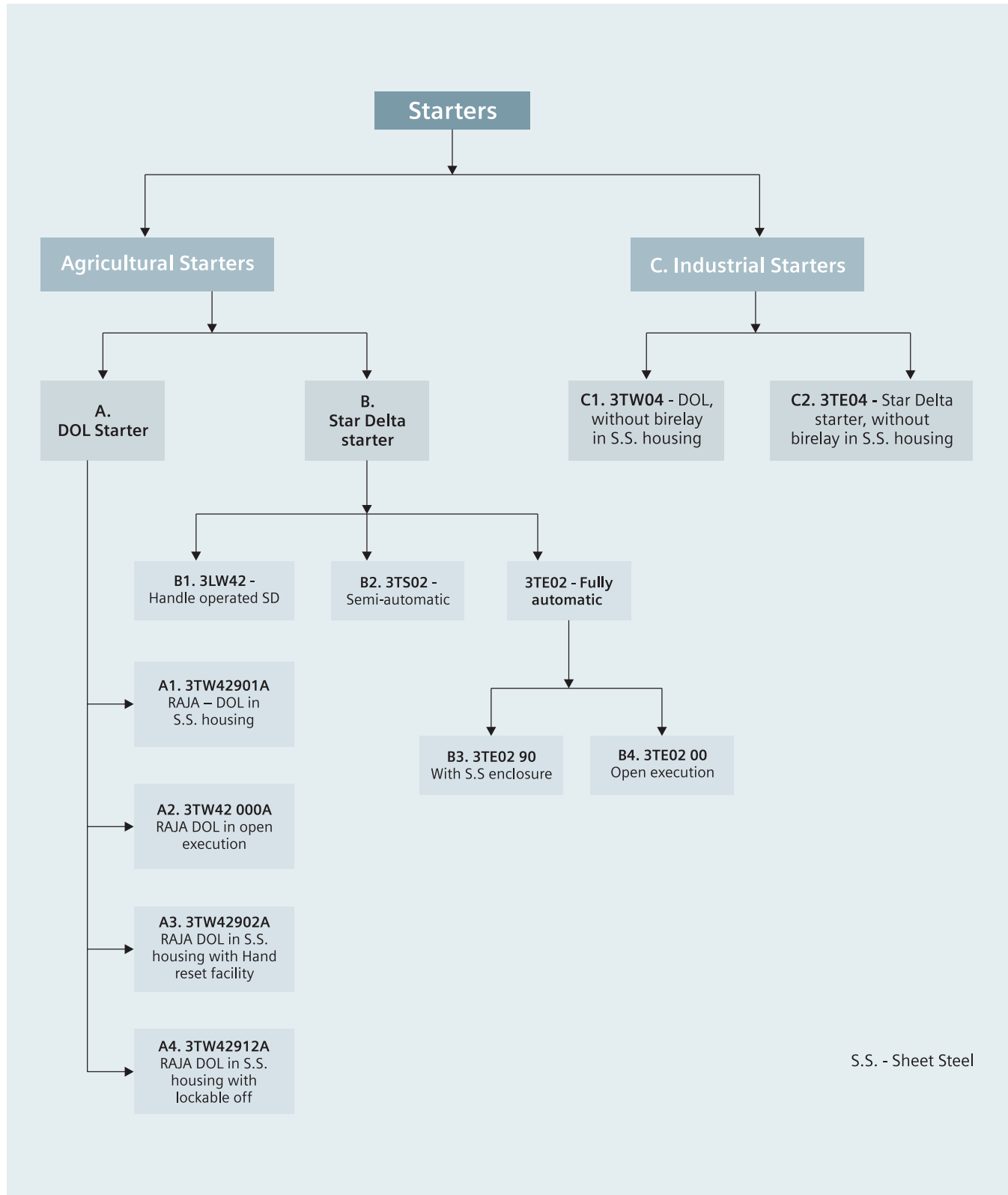

S.S. - Sheet Steel

Application

The main purpose of motor starters is to start the electrical motor by switching ON the contactor inside the starter. The relay inside the starter additionally protects the motor in case of overload and single phasing condition. The starter is nothing but a pre-wired assembly of contactor(s), relay and ON-OFF push buttons. Direct on line and star delta are two methods of starting the electric motors which is achieved by our DOL and star delta starter respectively.

Standard

Siemens starters confirms to IS/IEC 60947-4-1

Range

Agricultural starters

3TW42 DOL starters (A1, A2, A3, A4): upto 10Hp

3LW42 Handle operated star delta starters (B1): upto 15Hp

3TS02 Semi-automatic and 3TE02 fully automatic star delta starters (B2, B3, B4): upto 25Hp

Industrial starters

3TW04 DOL and 3TE04 star delta starters (C1, C2): upto 75Hp

Benefits and features

Flexibility

- **Starters with or without enclosure**
Pre-wired DOL as well as star delta starters are available either in open execution or in sheet steel enclosure.
- **Industrial starters without relay**
Industrial DOL as well as star delta starters have provision for mounting relay but the relay is not provided in the starter. Thus offering flexibility of selecting 3UA relay range as per customers requirement.

Reliability

- **Wide band coil voltage**
Agricultural DOL starters are having option of 200-400 V and agricultural star delta starters are having option of 230-400 V coil voltage which takes care of wide fluctuations in the supply voltage occurring especially in the remote places.

High performance

- **In-built single phasing protection**
In case of phase loss the current through the other two windings increases by 1.732 times the rated current of the motor. The current now flows only through the 2 bimetallic strips which should produce the required force on the tripping mechanism. This needs higher currents for longer time. As current is not too high so the relay might take higher time to trip. This can cause damage to the motor. Similar condition happens in case of phase unbalance. To take care of these conditions our birelays provided in the starters are constructed such that they offer a built-in single phasing protection using differential slider principle.



Ordering data

A1. DOL Starter in sheet steel housing, incl. birelay with single phasing protection

Motor rating at 415V, 3ph, 50Hz		Type ¹⁾ (DOL)	Relay range A	Std. pkg. (nos.)
HP	kW			
0.33	0.25	3TW42 90-1A.64	0.63-1	1
0.75	0.55	3TW42 90-1A.66	1-1.6	
1	0.75	■ 3TW42 90-1A.68	1.6-2.5	
1.5	1.1	3TW42 90-1A.69	2-3.2	
2	1.5	■ 3TW42 90-1A.71	3.2-5	
3	2.2	■ 3TW42 90-1A.72	4-6.3	
5	3.7	■ 3TW42 90-1A.74	6.3-10	
–	–	■ 3TW42 90-1A.75	8-12.5	
7.5	5.5	■ 3TW42 90-1A.77	10-16	
10	7.5	■ 3TW42 90-1A.78	12.5-20	

¹⁾ Enter code for coil voltage, 50Hz (B for 200-400V, W for 415V)

A2. Starter in open execution, incl. birelay with single phasing protection

Motor rating at 415V, 3ph, 50Hz		Type ¹⁾ (DOL)	Relay range A	Std. pkg. (nos.)
HP	kW			
0.33	0.25	3TW42000A.64	0.63-1	1
0.75	0.55	3TW42000A.66	1-1.6	
1	0.75	3TW42000A.68	1.6-2.5	
1.5	1.1	3TW42000A.69	2-3.2	
2	1.5	3TW42000A.71	3.2-5	
3	2.2	3TW42000A.72	4-6.3	
5	3.7	3TW42000A.74	6.3-10	
–	–	3TW42000A.75	8-12.5	
7.5	5.5	3TW42000A.77	10-16	
10	7.5	3TW42000A.78	12.5-20	

¹⁾ Enter code for coil voltage, 50Hz (B for 200-400V, W for 415V)

A3. Starter with lockable off, in sheet steel housing, incl. birelay with single phasing protection

Motor rating at 415V, 3ph, 50Hz		Type ¹⁾ (DOL)	Relay range A	Std. pkg. (nos.)
HP	kW			
0.33	0.25	3TW42912A.64	0.63-1	1
0.75	0.55	3TW42912A.66	1-1.6	
1	0.75	3TW42912A.68	1.6-2.5	
1.5	1.1	3TW42912A.69	2-3.2	
2	1.5	3TW42912A.71	3.2-5	
3	2.2	3TW42912A.72	4-6.3	
5	3.7	3TW42912A.74	6.3-10	
–	–	3TW42912A.75	8-12.5	
7.5	5.5	3TW42912A.77	10-16	
10	7.5	3TW42912A.78	12.5-20	

¹⁾ Enter code for coil voltage, 50Hz (B for 200-400V, W for 415V)

A4. Starter with hand reset facility, in sheet steel housing, incl. birelay with single phasing protection

Motor rating at 415V, 3ph, 50Hz		Type ¹⁾ (DOL)	Relay range A	Std. pkg. (nos.)
HP	kW			
0.33	0.25	3TW42902A.64	0.63-1	1
0.75	0.55	3TW42902A.66	1-1.6	
1	0.75	3TW42902A.68	1.6-2.5	
1.5	1.1	3TW42902A.69	2-3.2	
2	1.5	3TW42902A.71	3.2-5	
3	2.2	3TW42902A.72	4-6.3	
5	3.7	3TW42902A.74	6.3-10	
–	–	3TW42902A.75	8-12.5	
7.5	5.5	3TW42902A.77	10-16	
10	7.5	3TW42902A.78	12.5-20	

¹⁾ Enter code for coil voltage, 50Hz (B for 200-400V, W for 415V)

B1. Handle-operated star delta starter in sheet steel housing, incl. birelay with single phasing protection

Motor rating at 415V, 3ph, 50Hz		Type ¹⁾ (HSD)	Relay range	Std. pkg. (nos.)
HP	kW			
5	3.7	3LW42 90-0A.72	4-6.3	1
10	7.5	3LW42 90-0A.74	6.3-10	
12.5	9.3	3LW42 90-0A.75	8-12.5	
15	11	3LW42 90-0A.77	10-16	

¹⁾ Enter code for coil voltage, 50Hz (B for 200-400V, W for 415V)

B2. Semi-automatic star delta starter in sheet steel housing, incl. birelay with single phasing protection

Motor rating at 415V, 3ph, 50Hz		Type ²⁾ (SASD)	Relay range	Std. pkg. (nos.)
HP	kW			
12.5	9.3	3TS02 90-0A.75	8-12.5	1
15	11	3TS02 90-0A.77	10-16	
20	15	3TS02 90-0A.78	12.5-20	
25	18.5	3TS02 90-0A.79	16-25	

²⁾ Enter code for coil voltage, 50Hz (D for 230-400V, W for 415V)

B3. Automatic star delta starter in sheet steel housing, incl. birelay with single phasing protection

Motor rating at 415V, 3ph, 50Hz		Type ²⁾ (ASD)	Relay range	Std. pkg. (nos.)
HP	kW			
12.5	9.3	■ 3TE02 90-0A.75	8-12.5	1
15	11	■ 3TE02 90-0A.77	10-16	
20	15	■ 3TE02 90-0A.78	12.5-20	
25	18.5	■ 3TE02 90-0A.79	16-25	

²⁾ Enter code for coil voltage, 50Hz (D for 230-400V, W for 415V)

B4. Automatic star delta starter in open execution

Motor rating at 415V, 3ph, 50Hz		Type ²⁾ (DOL)	Relay range	Std. pkg. (nos.)
HP	kW			
12.5	9.3	3TE02000A.75	0.63-1	1
15	0.55	3TE02000A.77	1-1.6	
20	0.75	3TE02000A.78	1.6-2.5	
25	1.1	3TE02000A.79	2-3.2	

²⁾ Enter code for coil voltage, 50Hz (D for 230-400V, W for 415V)

C1. DOL starter in sheet steel housing (without birelay - to be ordered separately)

Motor rating at 415V, 3ph, 50Hz		Type ³⁾ (DOL)	Birelay (recommended)	Std. pkg. (nos.)
HP	kW			
20	15	■ 3TW04 94-2A..	3UA55 (20-32A)	1
25	18.5	■ 3TW04 95-2A..	3UA55 (25-36A)	
30	22	■ 3TW04 96-2A..	3UA58 (32-50A)	
40	30	3TW04 97-2A..	3UA58 (40-57A)	
50	37	3TW04 98-2A..	3UA58 (57-70A)	
75	55	3TW05 90-2A..	3UA5830 (85-105A)	

³⁾ Enter code for coil voltage, 50Hz ("RO" for 415V, "PO" for 230V)

C2. Automatic star delta starter in sheet steel housing (without birelay)

Motor rating at 415V, 3ph, 50Hz		Type ³⁾ (ASD)	Birelay (recommended)	Std. pkg. (nos.)
HP	kW			
30	22	■ 3TE04 94-2A..	3UA55 (16-25A)	1
40	30	■ 3TE04 94-2A..	3UA55 (20-32A)	
50	37	■ 3TE04 95-2A..	3UA55 (32-40A)	
60	45	3TE04 96-2A..	3UA58 (32-50A)	
75	55	3TE04 97-2A..	3UA58 (40-57A)	

³⁾ Enter code for coil voltage, 50Hz ("RO" for 415V, "PO" for 230V)

Relays and contactors used in the starters:

	MLFB	AC3 Rating @ 415V	Used in starter
Contactor	3TW0 290-0A.51 [#]	20	A1 to A4, B1
	3TW0 311-0A*51	25	B2 to B4
	3TW0 320-0A*51	25	B2 to B4
Relay	3UW5 002.. ⁵	16/20	All A & B

[#] Coil codes for contactor 3TW02

Coil voltage V, 50Hz	200-400	415
Code	B	W

* Coil codes for contactor 3TW03

Coil voltage V, 50Hz	230-400	220	415
Code	D	M	W

⁵ Coil codes for relay 3UW5:

Relay range	0.63-1	1-1.6	1.6-2.5	2-3.2	3.2-5	4-6.3	6.3-10	8-12.5	10-16	12.5-20	16-25
Code	0J	1A	1C	1D	1F	1G	1J	1K	2A	2B	2C

C. Industrial starter (starters w/o relay)









The 3TF contactor is available and 3UA relays are recommended.

Spares for starters

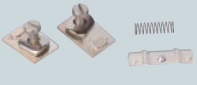

Spares for 3TW42 / 3LW42

CONTACTOR	3TW0 290-0A.51	
RELAY	3UW5002.. ⁵	
ON Actuator	3TX0 204-1YA0	
OFF Actuator	3TX0 204-1YB0	
Reset Actuator for HSD	3TX0 204-1YR0	
Coil	3TX0 203-0Y.6 [#]	
Arc chamber	3TX0 202-0YA0	
Main contact kit 1pole	3TX0 200-0YA1	
Main contact kit 3pole	3TX0 200-0YA0	
Moving contact carrier	3TX0 200-0YD0	
Aux fixed contact	3TX0 200-1YB0	
Aux moving contact	3TX0 200-1YC0	
On/off contact	3SX1 551-1YA	
Switch for HSD starter	3LA0 204-4YB	

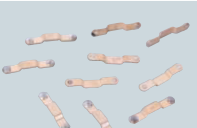
Spares for 3TE02

CONTACTOR	3TW0 311-0A*51	
CONTACTOR	3TW0 320-0A*51	
RELAY	3UW5002.. ⁵	
Main contact kit 3pole	3TX0 300-0YA0	
Main contact kit 1pole	3TX0 300-0YA1	
Coil	3TX0 303-0Y*6	
Aux fixed contact	3TX0 300-1YB0	
Aux fixed contact	3TX0 300-1YD0	
Aux moving contact	3TX0 300-1YC0	

Spares for other starters:

On/Off actuators	3SX1 552-1YA	
On/Off contact	3SX1 551-1YA	

Single line diagram SLD

DOL - in S.S. Housing SLD- 3phase motor

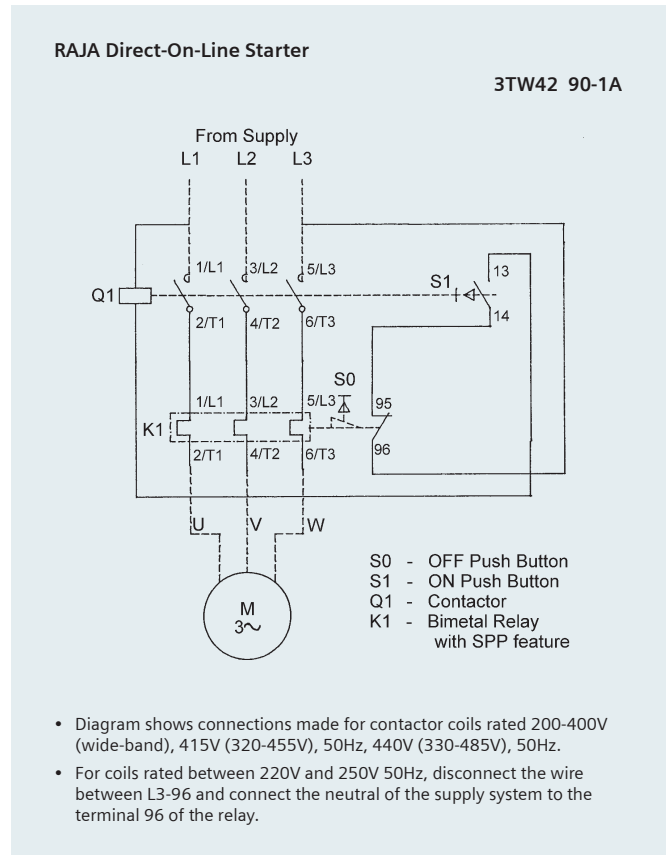

DOL - in S.S. Housing SLD- 1phase motor

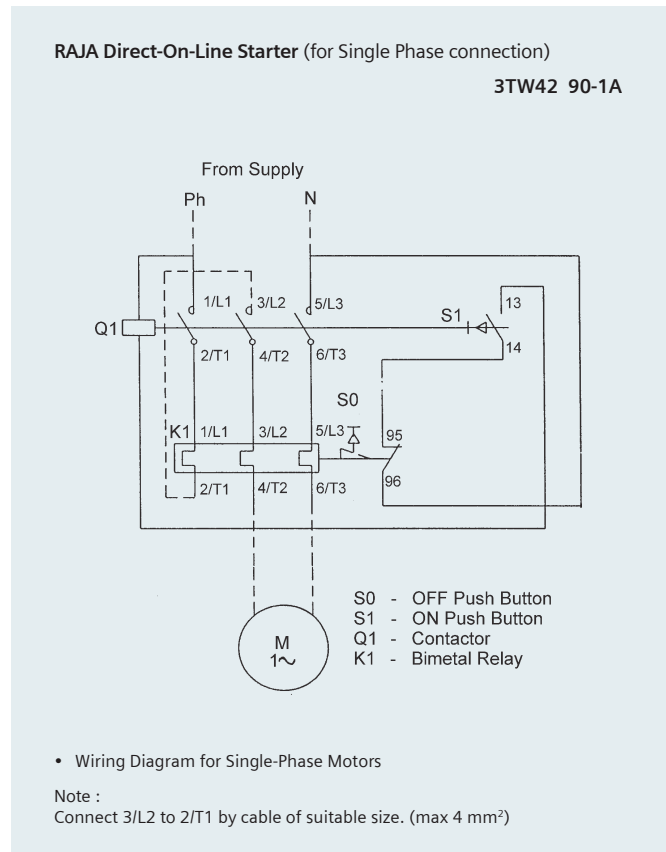

DOL - open execution SLD – 3phase motor

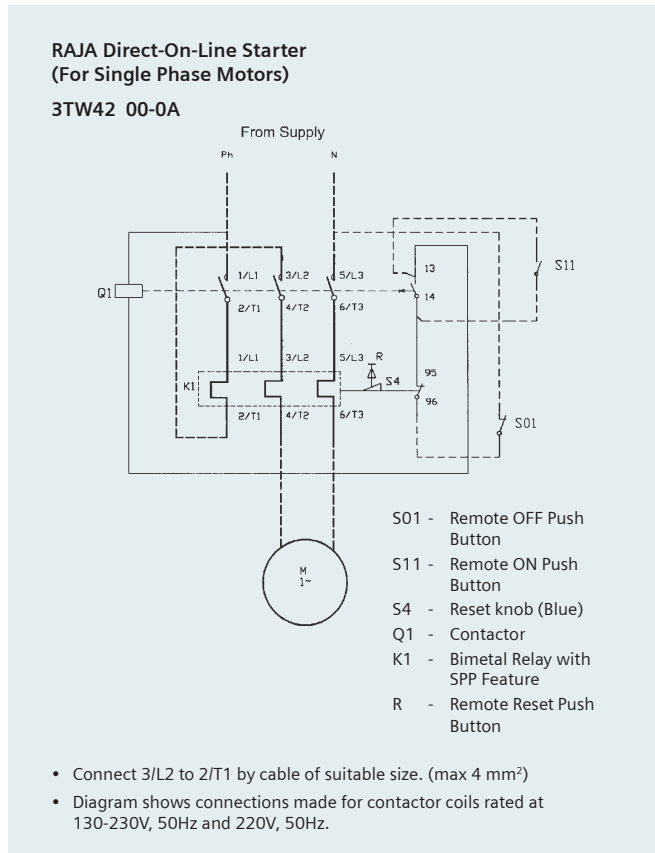

DOL – open execution SLD – 1 phase motor

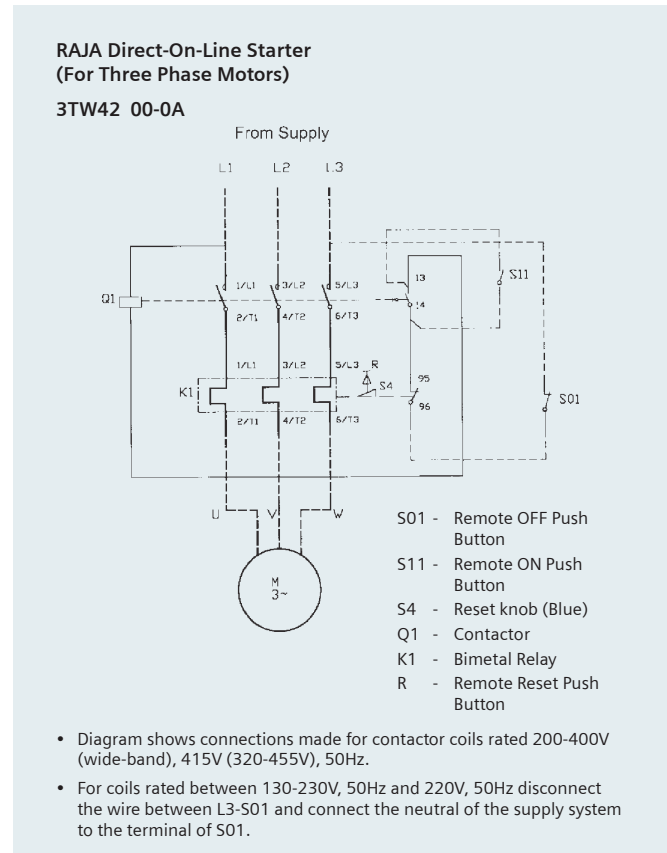

DOL – Remote reset - SLD

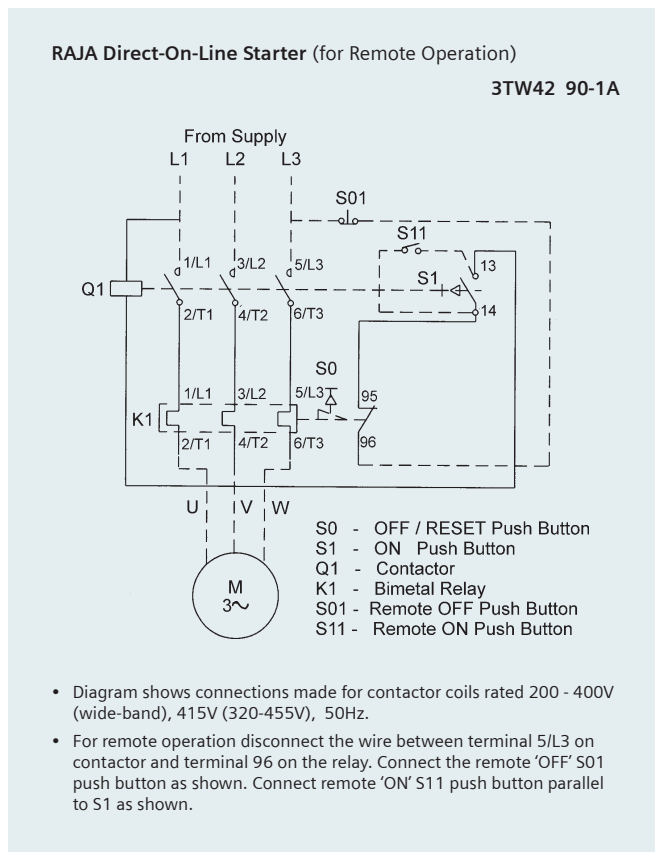

Handle Star delta Starter

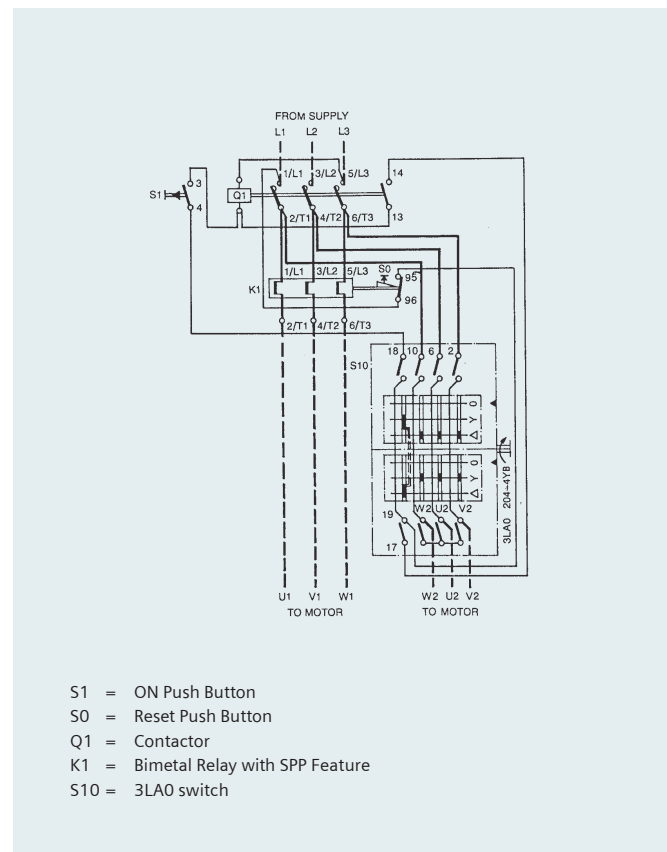

Star delta Starter

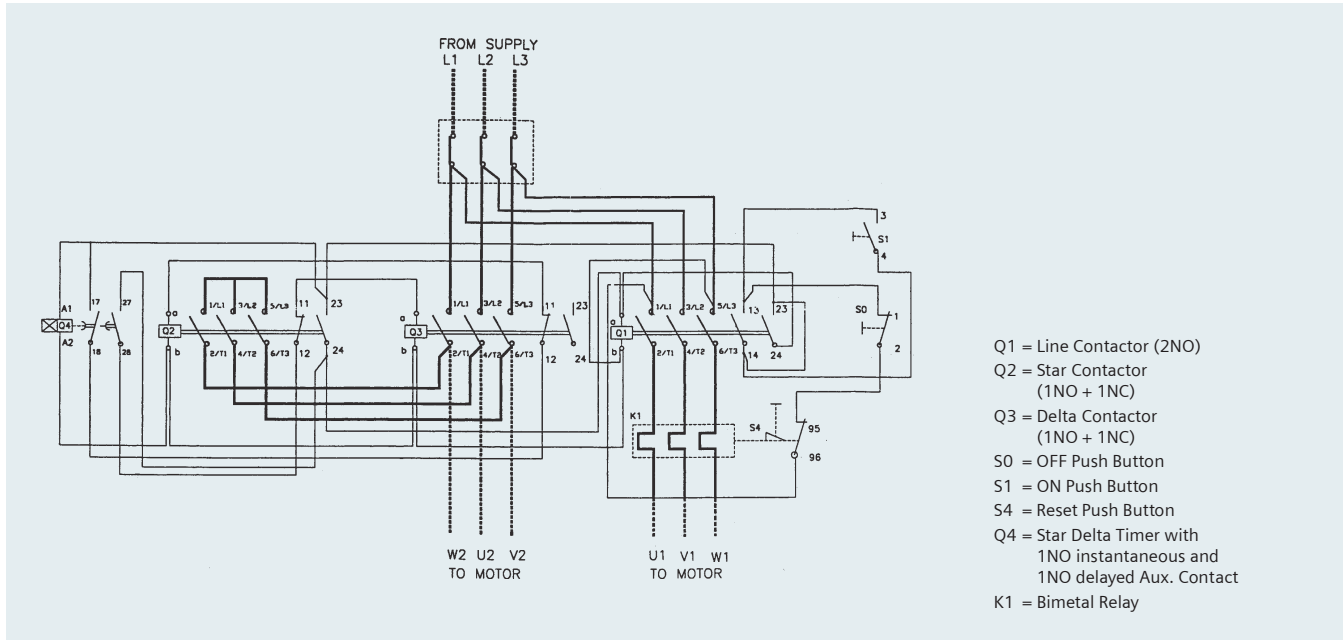

Dimensional drawings

A1: DOL starter in enclosure

A3: DOL with hand reset

A4: DOL with lockable off (here a small lock comes on the off push button which is not shown here below)

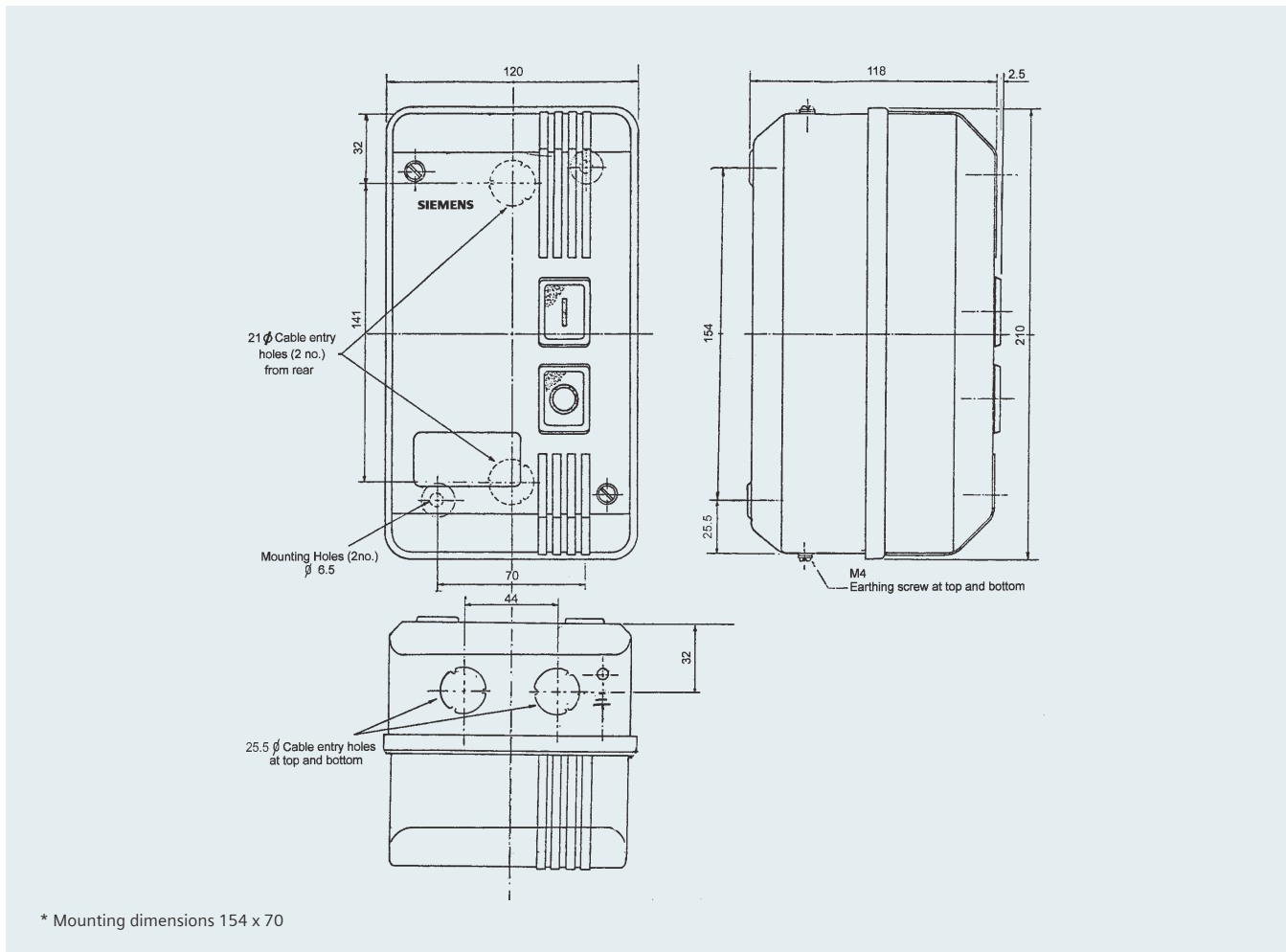

A2: DOL starter in open execution (contactor and relay are mounted on a plate)

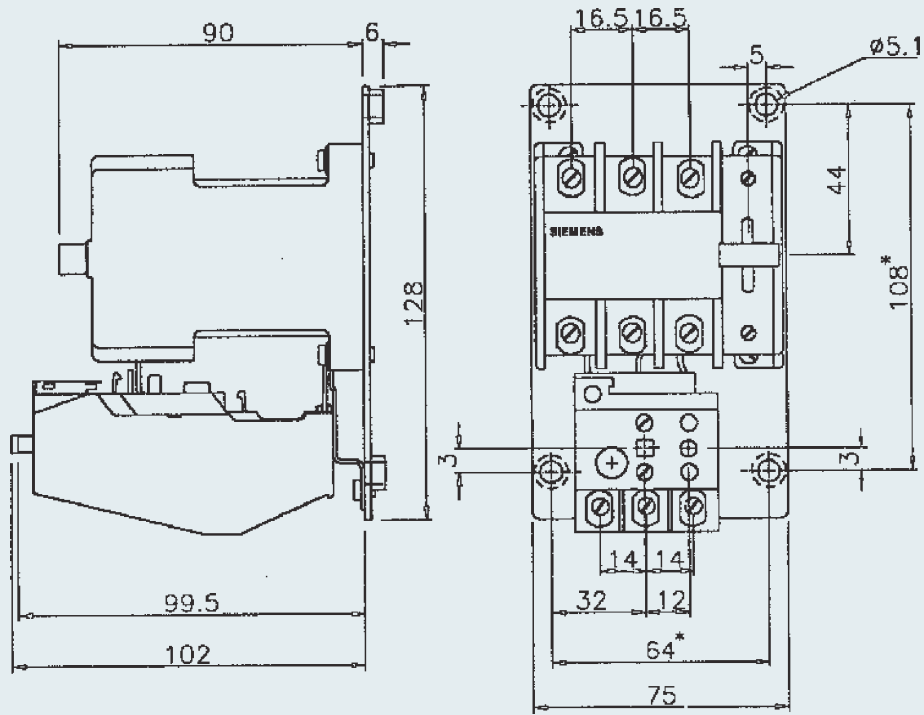

* Mounting dimensions 64 x 108 (Use M4 screws)

B1: Handle operated Star delta starter

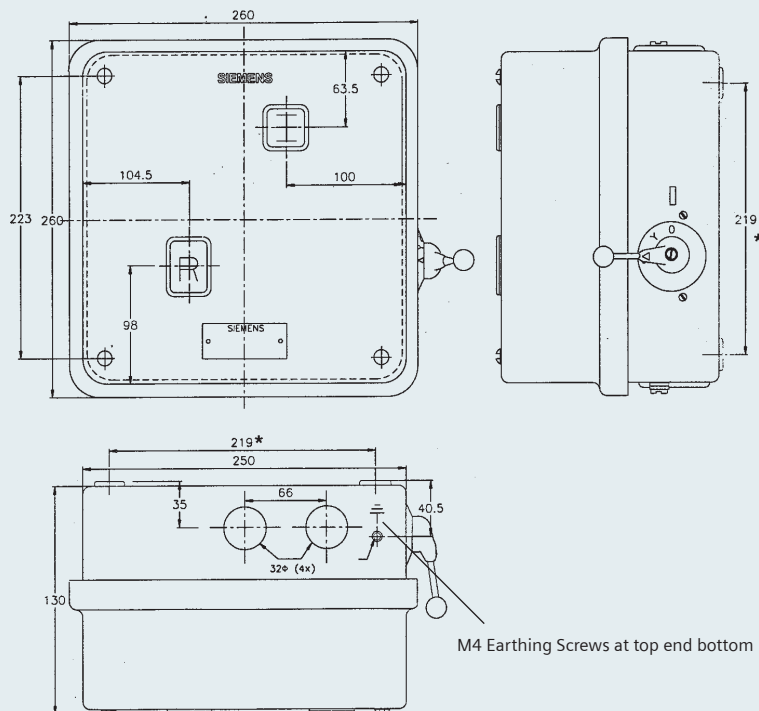

* Mounting dimensions 219 x 219
Use M4 screws for mounting

- B2: Semi automatic star delta starter and
- B3: Fully automatic star delta starter

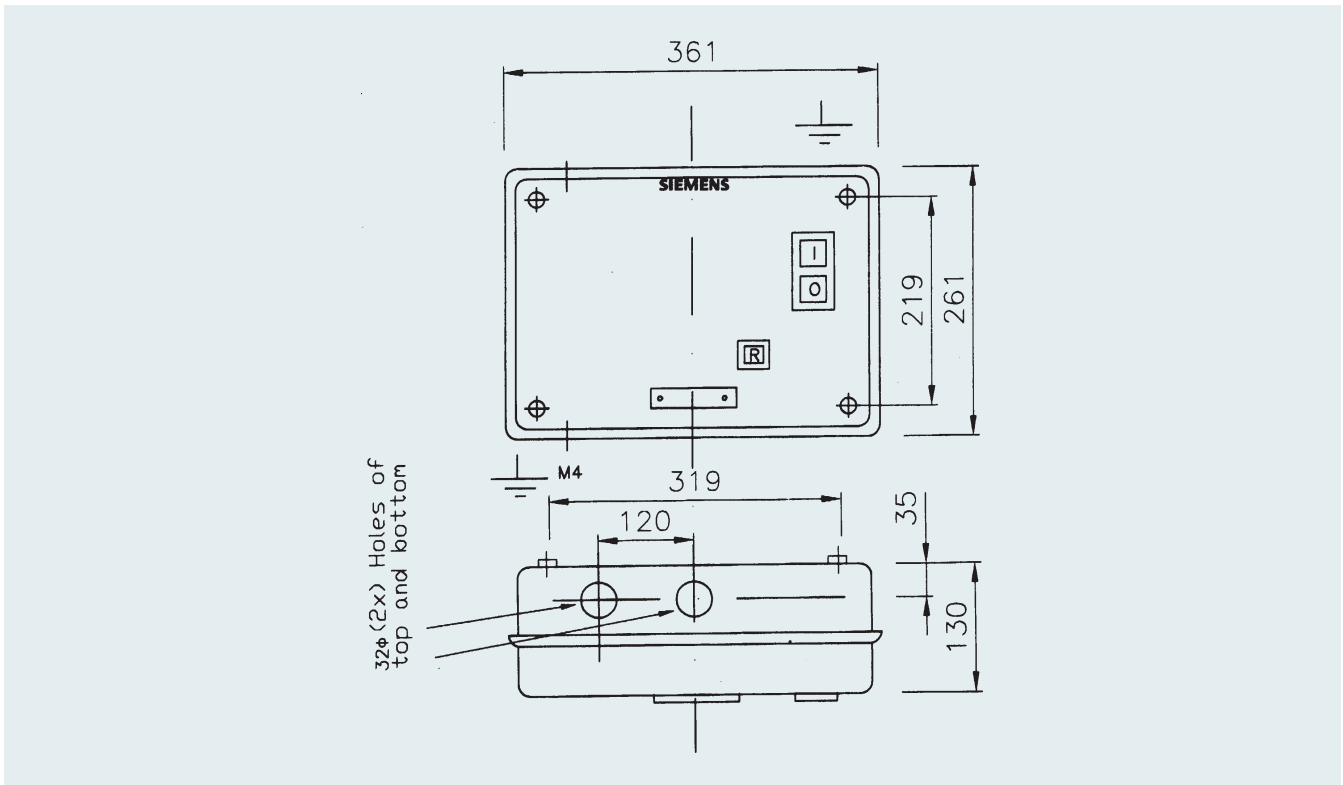

B4. Fully automatic star delta starter in open execution

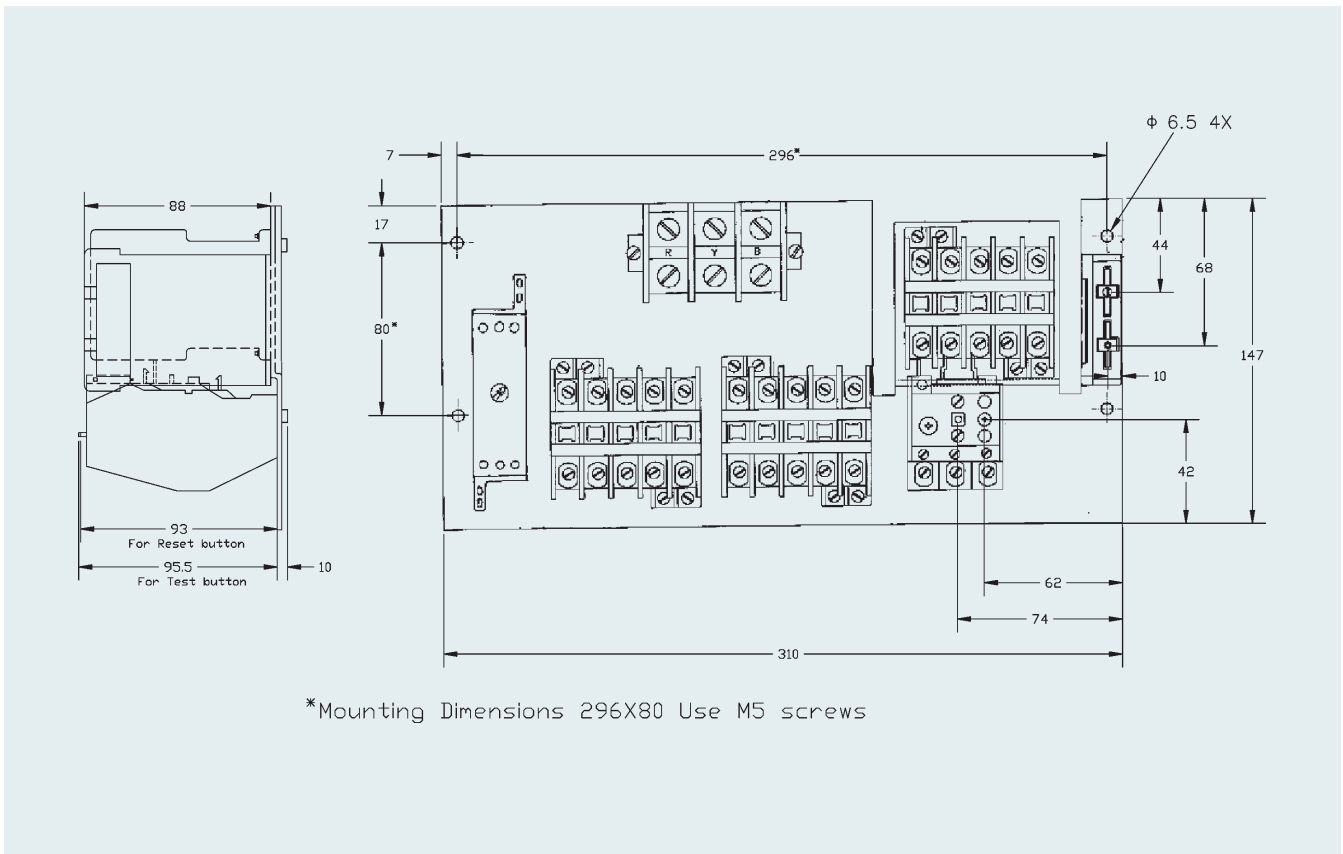

C1: DOL without relay

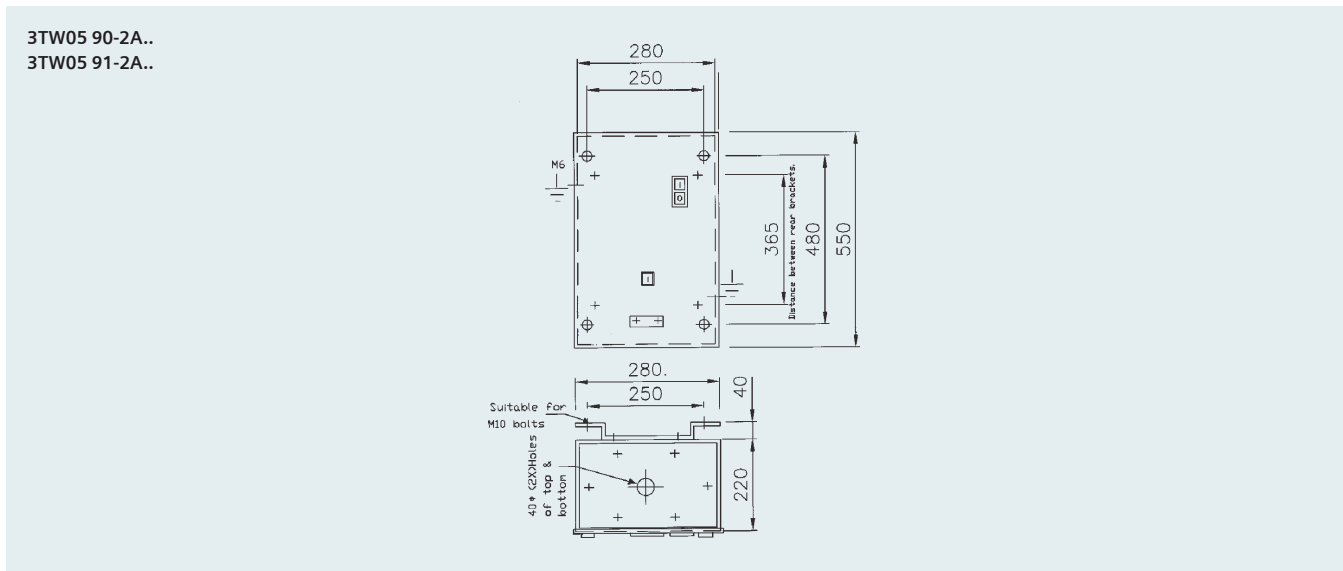
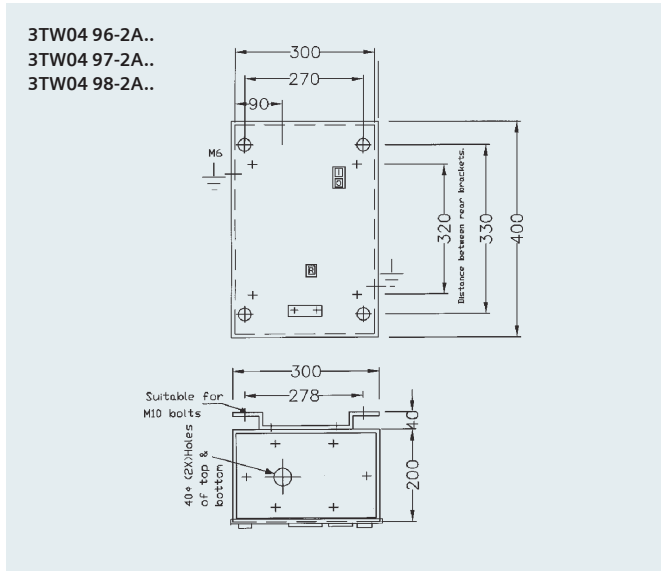
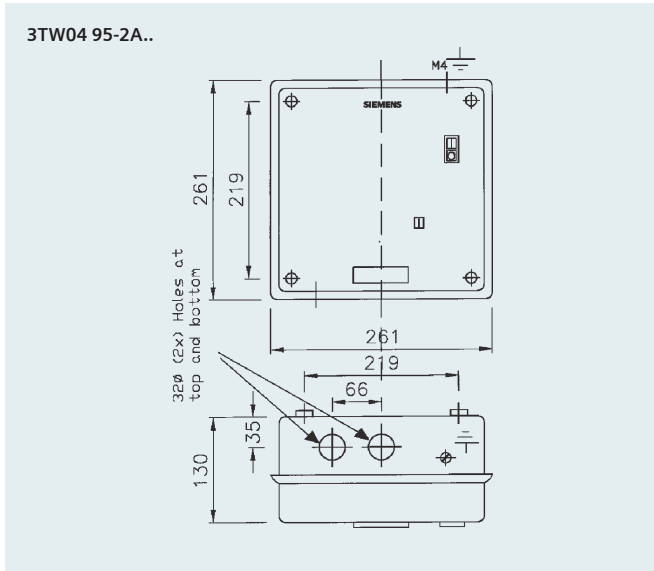

C2.

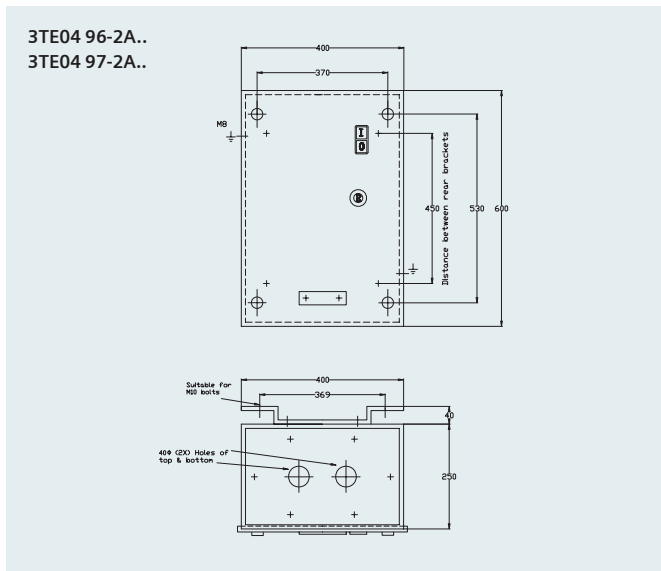
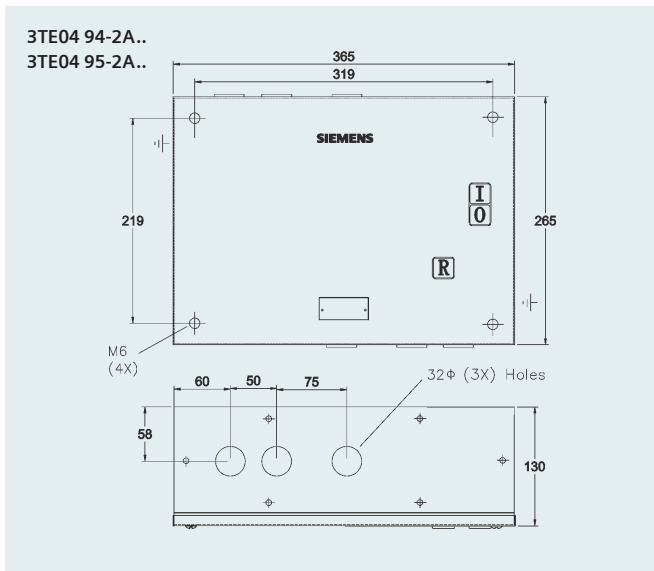

Useful technical information

Method of starting

A. DOL starting method:

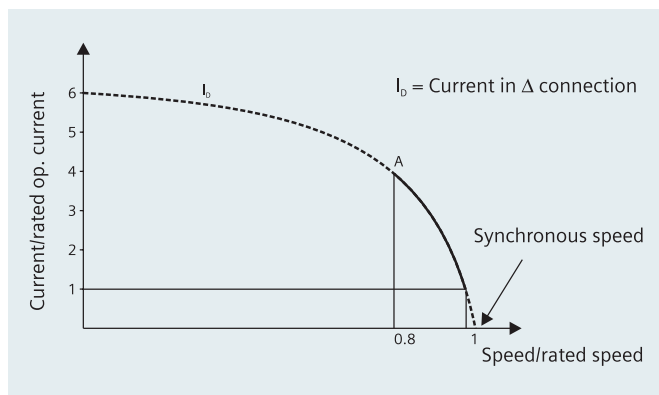

The most economical and popular method of starting squirrel cage induction motors, is direct-on-line, where the starter is connected directly across the supply. However, the starting current at the moment of switching Direct-on-line can be as high as 6-8 times the rated current.

Advantages: High starting torque, shorter starting time, simple construction and wiring, space saving etc.

Disadvantages: High starting current

Types:

Agricultural Starters

A1. RAJA DOL starter

Construction



Contactors:

The DOL starter up to 10 HP is fitted with 3TW02 contactor. This contactor is specially designed by Siemens considering the requirements of industry as well as agriculture. Considering the specific need of the agricultural pump set applications, Siemens has designed a special wide band coil (200- 400V). This coil operates reliably even when there is wide voltage fluctuation. The contact rating of this contactor is 20 A. This high contactor rating has made RAJA starter the most suitable starter for applications where current for given HP is higher than that of the conventional motors' e.g.. Submersible pumps etc.

Bimetal Overload Relay:

The RAJA direct-on-line starter is fitted with 3UW50 relay. These relays are computer calibrated and therefore, offer accurate protection. The main benefit of this bimetal relay is the built-in single phasing protection in addition to the overload protection. This relay is automatic reset type and can not be reset by hand.

Push buttons

Push buttons are used for switching 'ON' and 'OFF' the starter.

Operation:

In DOL starting, the 'ON' push button is pressed, which energizes the contactor coil, thus switching on the circuit. When the OFF' push button is pressed, the contactor is de-energized, switching off the circuit. The bimetal relay under normal functioning of motor plays no active part in the starter. But under overload, single phasing or locked rotor conditions of Motor, the bimetal relay cuts-off the supply to the contactor coil, tripping the circuit. The contactor itself provides the necessary 'no-voltage' protection in so far as it will drop out in the case of a supply failure, and for restarting on resumption of supply, the 'ON' push button will have to be pressed again.

A2. RAJA DOL starter in open execution:



This starter is exactly same as DOL starter with sheet steel housing except the enclosure and push buttons. The contactor and birelays are wired and mounted on the plate. It is expected that the user provides for the housing for this starter and also for the ON-OFF arrangement by way of push buttons or any other means.

A3. RAJA DOL starter with hand reset:

This starter is exactly same as RAJA DOL starter with sheet steel housing but in this case the relay needs to be reset manually. The OFF button on the housing is also used as reset button for resetting the relay after overload.



A4. DOL starter with lockable off:



This starter is exactly same as RAJA DOL starter with sheet steel housing but the relay needs to be reset manually by pressing OFF PB. Locking arrangement is provided for OFF push button; so starter can't be switched ON, inadvertently.

B. Star delta starting method:

In star delta starting, initially the motor windings are connected in star. This reduces the starting current by 1/3 rd of the full load current also the voltage by $(1/\sqrt{3})$ of the rated value. As the torque is proportional to the square of the voltage, the starting torque also get reduced to 1/3 rd of it's full load value. Once the motor attains approximately 80% of the rated speed, the windings get connected in the delta formation.

Thus by star delta starting, the starting current is reduced to 2 to 2.5 times the rated current unlike DOL starting, where it is 7 to 8 times of the rated current.

Advantages: low starting current

Disadvantages: Low / medium starting torque, longer starting time, less simpler construction and wiring, requires more space etc.

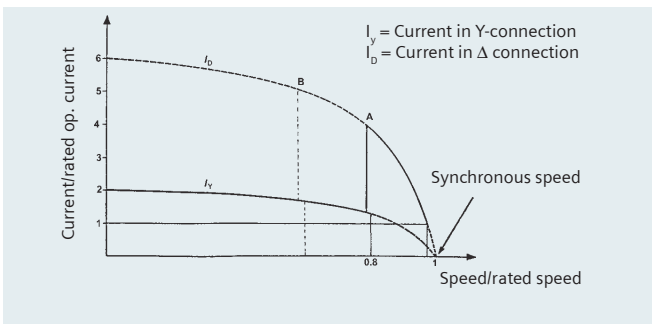

B1. Handle Operated Star Delta Starter (3LW42)



In this starter, the changeover from 'star' to 'delta' is done manually through a control switch.

Construction:

It consists of a star-delta switch (3LAO), contactor (3TW02), an overload relay (3UW50), "Reset" push button and a safety 'ON' push button.

Operation:

To start the motor, move the 3LAO switch handle from 'O' position to 'star' (Y) position with the right hand and press the start - (I) push button with your left hand. The motor starts and when it has almost come to its rated speed (indicated when the motor hum reaches a steady pitch), turn the handle to 'delta' position, still ensure to keep the push button pressed. After switching to delta, the push button and the switch handle can be released. To stop the motor, bring the handle of the switch to 'O' position. If the starter trips automatically due to any fault, the switch handle is first to be brought to 'O' position and the bimetal relay has to be reset.

B2. Semi automatic Star-Delta Starter (3TS02)

In this starter, the changeover from 'star' to 'delta' is done manually by pressing ON push button.



Construction:

It consists of three contactors (3TW03), bimetal overload relay (3UW50), and push buttons (ON-OFF, Reset) for control command.

Operation:

To start the motor, ON' push button is pressed and the same is hold for 6 to 8 sec (starting time of the motor). After 6-8 sec, it is left. After this, motor automatically changes over from star to delta. The OFF push button has been provided to switch off the entire circuit.

B3. Fully automatic Star-Delta Starter (3TE02)

In this starter, the changeover from 'star' to 'delta' is done automatically after a preset time by using a timer.



Construction:

It consists of three contactors (3TW03), bimetal overload relay (3UW50), electronic timer (3RP) for automatic changeover from 'star' to 'delta' and push buttons (ON-OFF, Reset) for control command.

Operation:

To start the motor, ON' push button is pressed, the line contactor and the star contactor switch-on connecting motor windings in star formation on reduced voltage. After the preset time, the timer automatically switches off the 'star' contactor and switches 'ON' the 'delta' contactor, thus after the starting period, the motor runs on full voltage. The OFF push button has been provided to switch off the entire circuit.

B4. Fully automatic star delta starter in open execution



This starter is exactly same as fully automatic starter in sheet steel housing expect the enclosure and push buttons. The contactor and birelays are wired and mounted on the plate.

C. Industrial Starter:

C1. DOL (3TW04):



This starter is similar to RAJA DOL starter with sheet steel housing (3TW42901A). In order to offer flexibility of selecting exact 3UA relay range by the customer, this starter has only provision for mounting the bi-relay but the birelay is not provided in the starter. Customer is required to select the suitable bi-relay and mount it in the starter before putting it in service.

C2. Star Delta (3TE04):



This starter is similar to star delta starter with sheet steel housing (3TE02). In order to offer flexibility of selecting exact 3UA relay range by the customer, this starter has only provision for mounting the bi-relay but the birelay is not provided in the starter. Customer is required to select the suitable bi-relay and mount it in the starter before putting it in service.